

Oval Undercut, Phillips & Slotted HEAD DIMENSIONS

ECOM
Fasteners

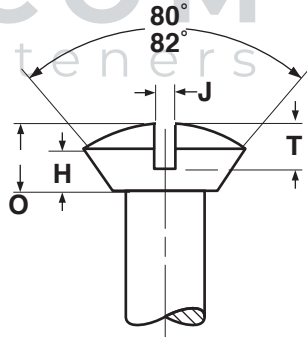

Slotted

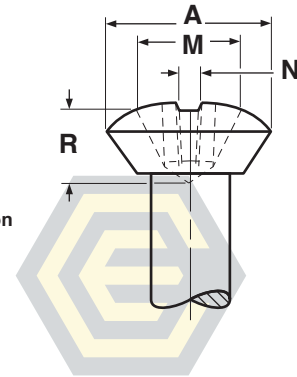
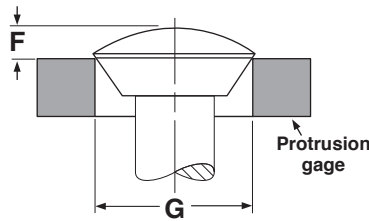

Phillips

ECOM
Fasteners

UNDERCUT OVAL HEADS FOR MACHINE SCREWS																	ASME B18.6.3-2013	
Nominal Size	These Lengths or Shorter are Undercut	A		H	O		J		T		M	R	N	F		G	Phillips Driver Size	
		Head Dimensions						Slot Dimensions				Recess Dimensions			Protrusion Above Gaging Diameter			Gaging Diam.
		Diameter		Side Height	Total Height		Width		Depth		Diam.	Depth	Width	Max	Min			
		Max	Min	Max	Max	Min	Max	Min	Max	Min	Max	Min	Max	Max	Min			
0	1/8	0.112	0.096	0.025	0.046	0.033	0.023	0.016	0.028	0.022	0.068	0.036	0.014	0.047	0.031	0.078	0	
1	1/8	0.137	0.120	0.031	0.056	0.042	0.026	0.019	0.034	0.027	0.070	0.039	0.015	0.053	0.035	0.101	0	
2	1/8	0.162	0.144	0.036	0.065	0.050	0.031	0.023	0.040	0.033	0.106	0.060	0.018	0.058	0.039	0.124	1	
3	1/8	0.187	0.167	0.042	0.075	0.059	0.035	0.027	0.047	0.038	0.118	0.072	0.019	0.064	0.044	0.148	1	
4	3/16	0.212	0.191	0.047	0.084	0.067	0.039	0.031	0.053	0.043	0.130	0.086	0.019	0.069	0.048	0.172	1	
5	3/16	0.237	0.215	0.053	0.094	0.076	0.043	0.035	0.059	0.048	0.152	0.073	0.028	0.075	0.053	0.196	2	
6	3/16	0.262	0.238	0.059	0.104	0.084	0.048	0.039	0.065	0.053	0.172	0.092	0.030	0.080	0.057	0.220	2	
8	1/4	0.312	0.285	0.070	0.123	0.101	0.054	0.045	0.078	0.064	0.186	0.107	0.031	0.091	0.066	0.267	2	
10	5/16	0.362	0.333	0.081	0.142	0.118	0.060	0.050	0.090	0.074	0.202	0.125	0.033	0.102	0.075	0.313	2	
12	3/8	0.412	0.380	0.092	0.161	0.135	0.067	0.056	0.103	0.085	0.264	0.140	0.038	0.113	0.084	0.362	3	
1/4	7/16	0.477	0.442	0.107	0.186	0.158	0.075	0.064	0.119	0.098	0.284	0.160	0.040	0.129	0.095	0.424	3	
5/16	1/2	0.597	0.556	0.134	0.232	0.198	0.084	0.072	0.149	0.124	0.374	0.214	0.064	0.155	0.117	0.539	4	
3/8	9/16	0.717	0.670	0.161	0.278	0.239	0.094	0.081	0.179	0.149	0.394	0.233	0.066	0.182	0.139	0.653	4	
7/16	5/8	0.760	0.715	0.156	0.279	0.239	0.094	0.081	0.184	0.154	0.404	0.245	0.068	0.195	0.150	0.690	4	
1/2	3/4	0.815	0.765	0.156	0.288	0.244	0.106	0.091	0.204	0.169	0.416	0.257	0.070	0.212	0.163	0.739	4	

Fasteners